

# CRX Series Built-In Refrigerators/Freezers

## Freezer Slides Out For More Space & Versatility



With many innovative features, the CRX is a durable built-in refrigerator that is quiet, flexible and efficient. It is available in five sizes with storage capacities from 1.6 to 4.6 cu. ft.

Dometic's patented removable freezer—an easy slide-out compartment—transforms the CRX into a refrigerator only, or a freezer only with temperatures going down to 17°F (-8°C).

The CRX is the first marine fridge to have an electronic control panel that fits flush into the side wall to provide more storage space and is within easy reach to operate. An infrared (IR) sensor replaces the less-reliable mechanically activated switch for illuminating the interior. The panel also contains soft-touch buttons for power and temperature setting, a bright LED light for illumination, a power-indicator LED, and an error-indicator LED that flashes system diagnostic codes.

The powerful speed-controlled compressor reduces noise when operating at the temperature set point. At start-up, the compressor runs at mid speed, switches to high speed for temperature pull down, then runs at a quiet low speed while maintaining the set point. The cooling system is enhanced with a tube and fin condenser that provides greater performance, durability, and corrosion resistance over the traditional wire condenser. A large fan provides better cooling performance, especially in high ambient temperatures.

Designed to eliminate vibration and enhance durability, the CRX has assured clearance between components and tubing, and a foamed mounting plate gives all components a solid and quiet mounting base.

CRX refrigerators with black or silver finish include a flush-mount or space-saver flange (to be specified when ordering). For stainless-steel models, the flange is purchased separately.



Full-width freezer compartment with door is removable to create either a larger capacity refrigerator-only or freezer-only, with temperatures going down to 17°F.



Flush-mount control panel features soft-touch temperature adjustment, on/off switch, and bright LED lamp triggered by a reliable IR sensor.



Available with one-piece stainless-steel wrapped door with wide-style latch.

### Key Benefits

- Patented removable freezer compartment transforms the unit into a larger-capacity refrigerator-only or 17°F (-8°C) freezer-only (CRX-1050, -1065, and -1080)
- Speed-controlled compressor is more efficient and reduces noise
- Large fan overcomes high ambient temperatures
- Bright LED illumination
- Flat electronic control panel
- High-performance tube and fin condenser
- Reliable IR sensor activates bright interior LED light
- Interior mounted electronic thermistor for accurate temperature measurements
- When connected, the built-in drain will eliminate condensate when de-icing and liquids that spill inside the unit
- Available in black, silver or stainless steel
- Black and silver models include a flush-mount or space-saver flange (must be specified when ordering)
- Flush-mount or space-saver flange must be ordered separately for stainless-steel models

### Special Options

- Flush-mount or space-saver flange for stainless-steel models

## Specifications for CRX Series Built-In Refrigerators

Model	CRX-1050	CRX-1065	CRX-1080	CRX-1110 <sup>(1)</sup>	CRX-1140 <sup>(1)</sup>
Total Storage Capacity (l/cf)	45/1.6	55/1.9	73/2.6	104/3.7	130/4.6
Amps @ 12VDC	5.0	5.5	5.6	6.2	7.7
Amps @ 24VDC	2.6	2.8	2.9	3.0	3.6
Amps @ 100VAC	1.14	1.22	1.23	0.82	0.95
Amps @ 240VAC	0.53	0.58	0.56	0.34	0.40
Overall Flush-Mount Flange Dimensions (H x W x D)	22.25 x 17.875 x 19.75 in. (556 x 524 x 502 mm)	21.875 x 20.625 x 21.5 in. (556 x 524 x 547 mm)	26.375 x 21.625 x 21 in. (670 x 550 x 534 mm)	30.5 x 23.375 x 22 in. (775 x 594 x 559 mm)	33.25 x 23.625 x 24.375 in. (845 x 600 x 620 mm)
Flush-Mount Flange Cutout Dimensions (H x W x D)	21.375 x 16.125 x 19.75 in. (543 x 410 x 502 mm)	21 x 18.875 x 21.5 in. (534 x 480 x 547 mm)	25.5 x 19.875 x 21 in. (648 x 505 x 534 mm)	29.625 x 21.625 x 22 in. (753 x 550 x 559 mm)	32.375 x 21.875 x 24.375 in. (823 x 556 x 620 mm)
Overall Space-Saver Flange Dimensions (H x W x D)	22.125 x 17.25 x 17.5 in. (562 x 439 x 445 mm)	21.75 x 20 x 19.25 in. (553 x 508 x 489 mm)	26.25 x 21 x 18.75 in. (667 x 534 x 731 mm)	30.375 x 22.75 x 19.75 in. (772 x 578 x 502 mm)	33.125 x 23 x 22.125 in. (816 x 585 x 562 mm)
Space-Saver Flange Cutout Dimensions (H x W x D)	21.125 x 15.25 x 17.5 in. (527 x 458 x 489 mm)	20.75 x 18 x 19.25 in. (527 x 458 x 489 mm)	25.25 x 19 x 18.75 in. (642 x 483 x 477 mm)	29.375 x 20.75 x 19.75 in. (477 x 727 x 502 mm)	32.125 x 21 x 22.125 in. (816 x 534 x 562 mm)
Net Weight (lbs/kg)	35.3/16	39.7/18	44.1/20	TBD	TBD

<sup>1</sup> Freezer not removable

### About the Flange



CRX refrigerators in black and silver finish come standard with a flange to match the door panel color. In the flush-mount position, the flange provides a pleasing cosmetic appearance and eliminates a protruding handle or locks. In the space-saver position, the flange is set about an inch back for installations where cabinet depth is limited. The flange must be ordered separately for stainless-steel CRX models.

### About the Speed-Controlled Compressor



Unique to the CRX series, the speed-controlled compressor runs at mid speed when starting up, switches to high speed for temperature pull down, then runs at low speed while maintaining the set point. The result is a quieter unit that runs more efficiently. The tube-and-fin condenser provides greater performance, durability, and corrosion resistance over the traditional static condenser. The large fan provides better cooling performance, especially in high ambient temperatures.

#### DOMETIC MARINE DIVISION

2000 N. Andrews Ave. Ext. | Pompano Beach, FL 33069 USA | Tel. 954-973-2477 | Fax: 954-979-4414  
www.Dometic.com/Marine | MarineSales@DometicUSA.com

#### 24/7 TECH SUPPORT FOR UNITED STATES & CANADA:

8:00 AM to 5:00 PM Eastern Time: 800-542-2477  
After hours and weekends: 888-440-4494

#### INTERNATIONAL SALES & SERVICES

Europe & the Middle East: Call +44(0)870-330-6101  
For all other areas visit our website to find your nearest distributor.

### Dimensions

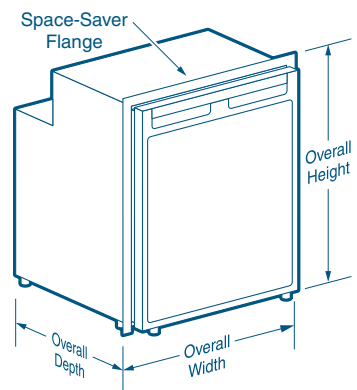
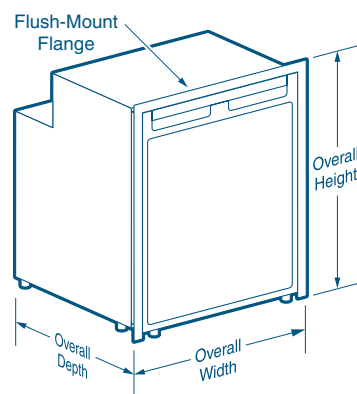

Dealer

